

- 1. HR-MAX profile (Ref. C1829)
- 2.1 Gland (item 2.1)*
- 2.2 Gland (item 2.2)*
- 3. End cap*
- 4. End cap screw*
- 5. LED tape with cable*
- 6. Cover*
- 7.1 Hermetic coupler (item 7.1)*
- 7.2 Hermetic coupler (item 7.2)*
- 7.3 Hermetic coupler (item 7.3)*
- 7.4 Hermetic coupler (item 7.4)*

- 8.1 Connector (item 8.1)*
- 8.2 Connector (item 8.2)*
- 9.1 Angled gland (item 9.1)*
- 9.2 Angled gland (item 9.2)*

optional

*The full range of accessories and electronics is available at www.KlusDesign.eu

NOTE! All LED tapes must be connected to a 12 V or 24 V power supply.

IMPORTANT: Not all possible mounting procedures are presented here. More mounting procedures and related accessories can be found at www.KlusDesign.eu. Drawings of extrusions and accessories in these instructions are simplified and only approximate the actual shapes.

I

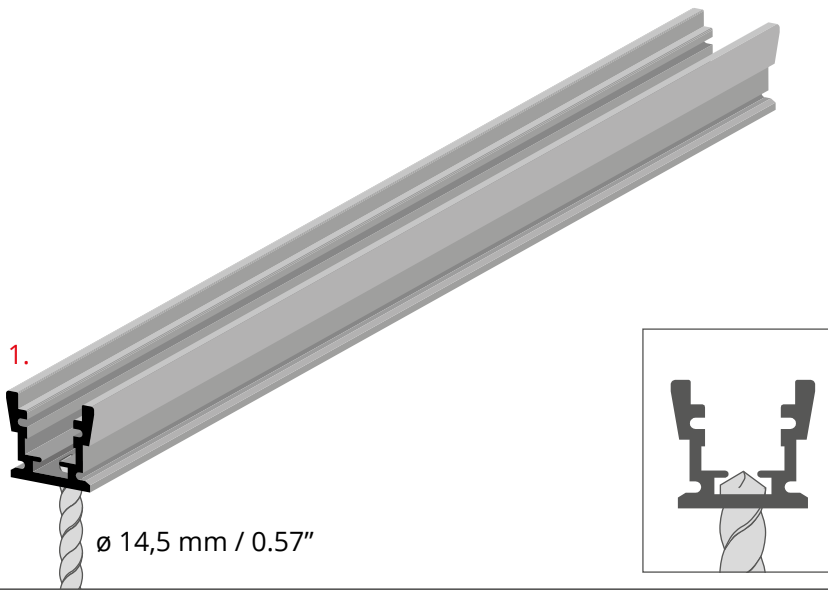

Drill a hole for the gland in the HR-MAX profile (1).

II

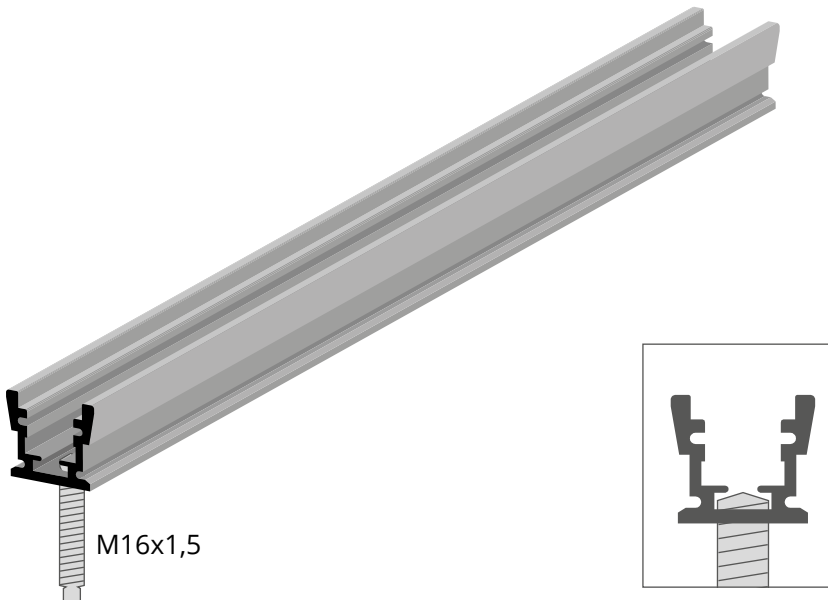

Tap the pre-drilled hole.

III

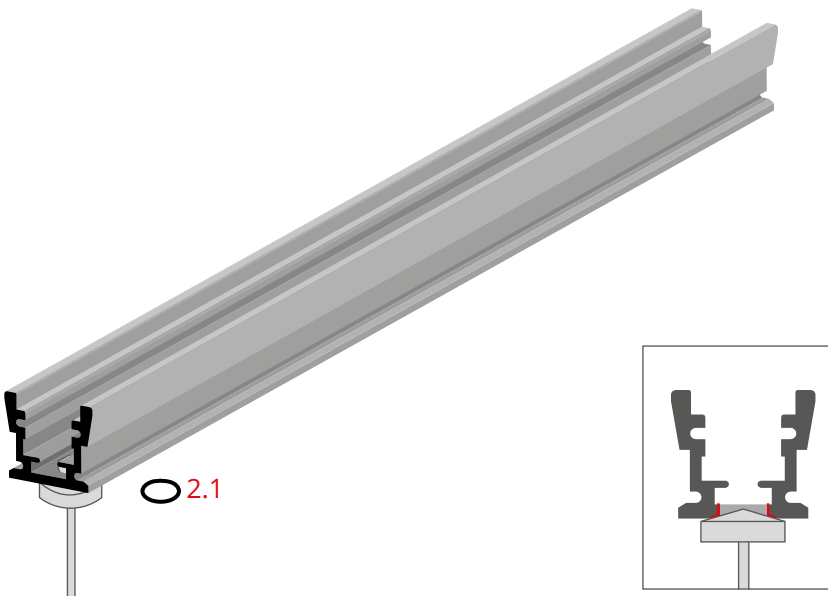

Chamfer the hole to hide the gland item (2.1) in the recess.

IV

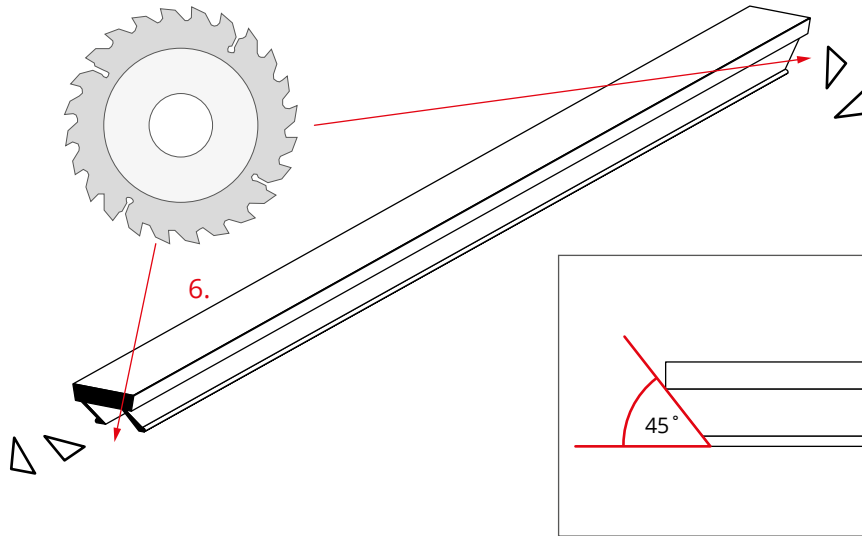

Cut the arms of the cover (6) at its ends at a 45° angle.

V

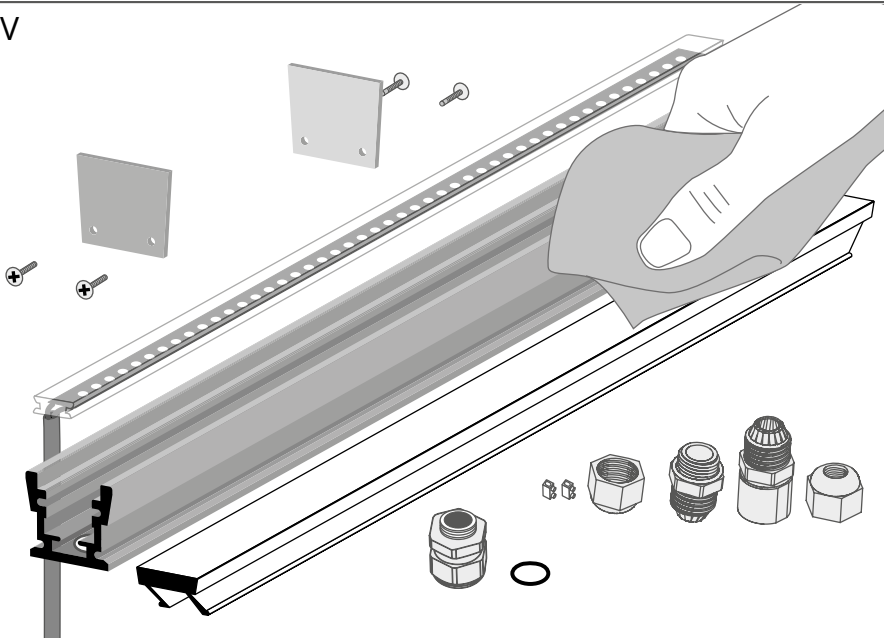

Remove dust and dirt from all parts of the lighting fixture.

VI

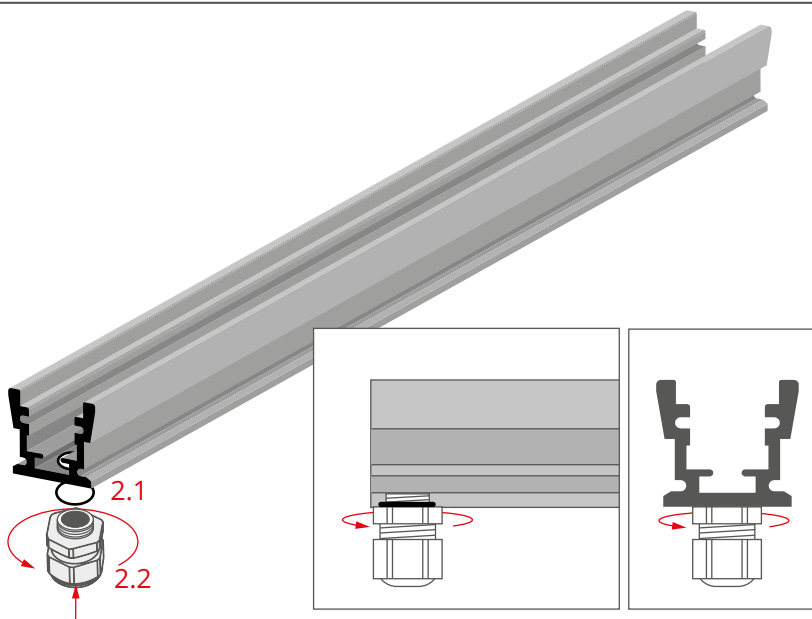

Place the gland item (2.1) in the recess and screw the gland item (2.2) into the hole.

VII

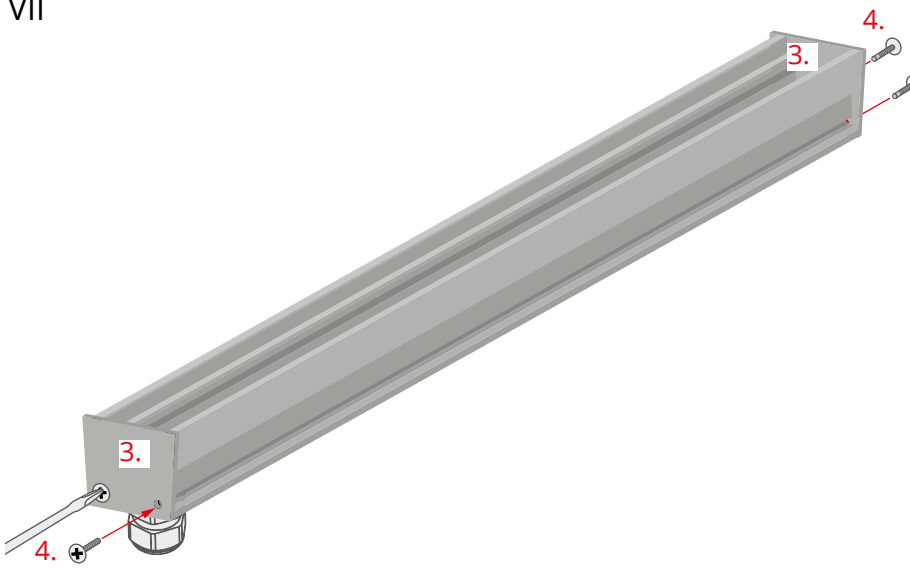

Attach the end caps (3) and lock them with the screws (4).

VIII

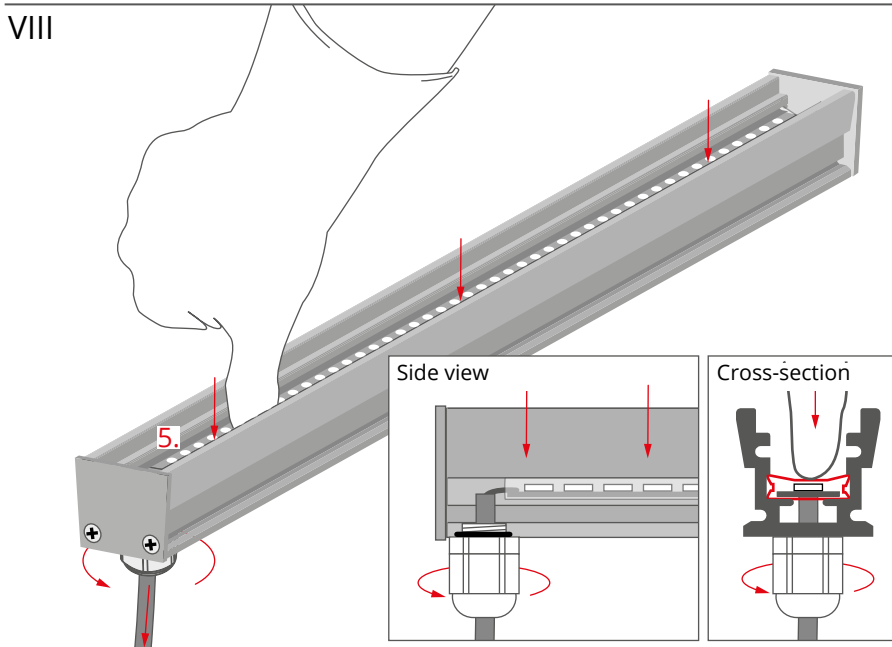

Place the LED tape (5) in the chamber inside the profile. The silicone sleeve will help you lock the tape in the designated position.

Pull the cable through the gland and tighten it.

IX

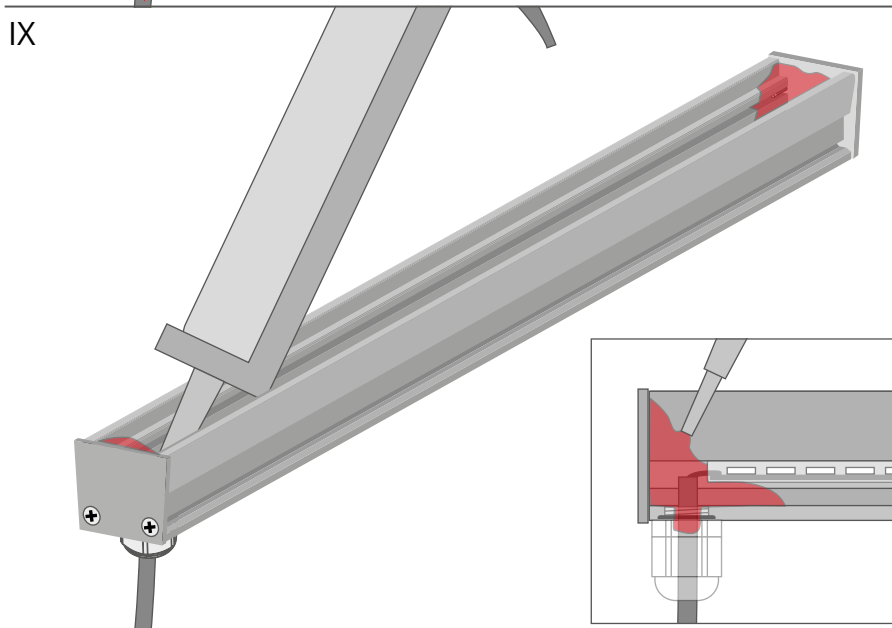

Fill the tightened gland and the entire space inside the profile near the end caps with silicone.

X

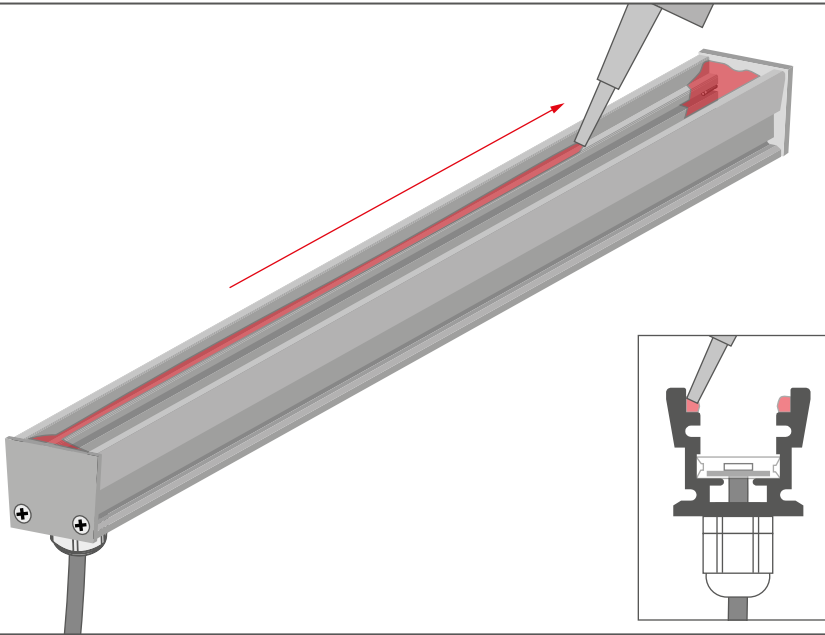

Apply silicone to the edges of the profile marked in the drawing.

XI

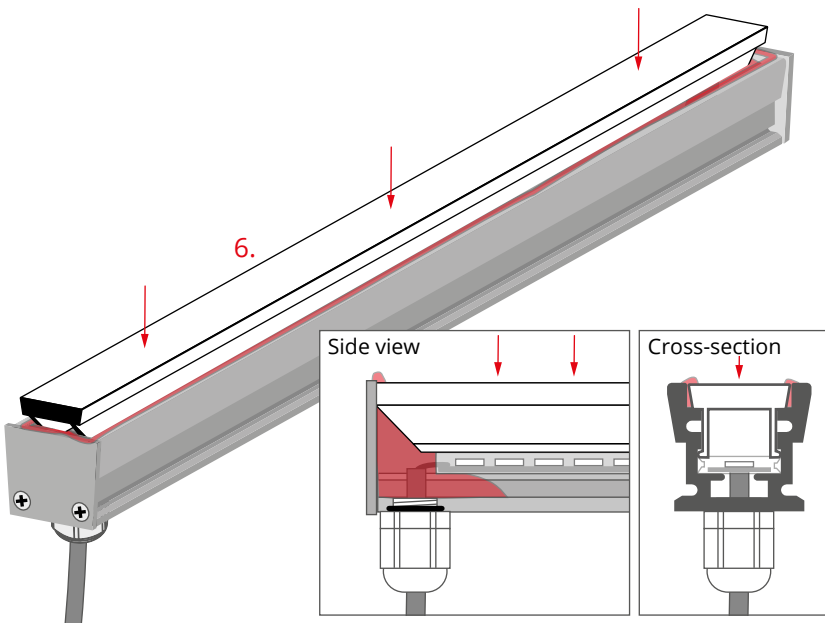

Insert the cover (6) in the profile and press it down against the LED tape. The excess silicone should flow up onto the profile surface.

XII

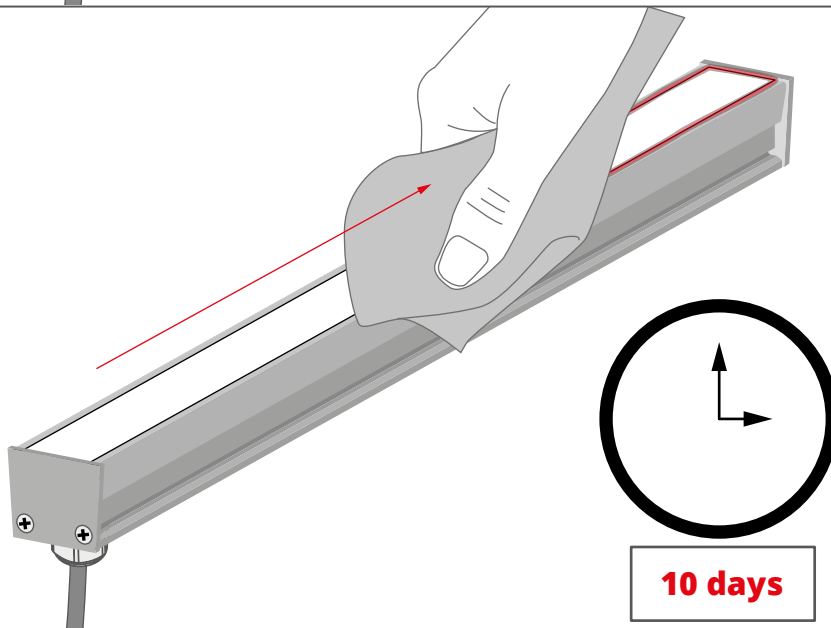

Wipe the fixture. The drying time is 10 days.

XIII

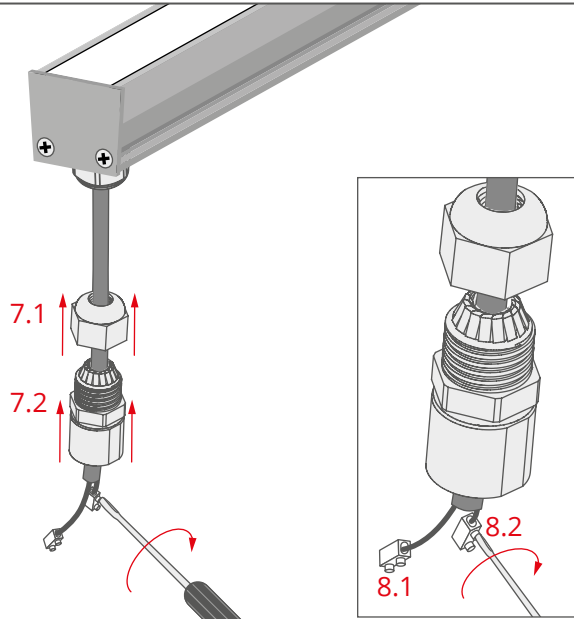

Put items (7.1, 7.2) of the hermetic coupler and both items of the connector (8.1, 8.2) on the cable.

NOTE! Connector items must be far enough not to touch each other when placed inside the coupler.

XIV

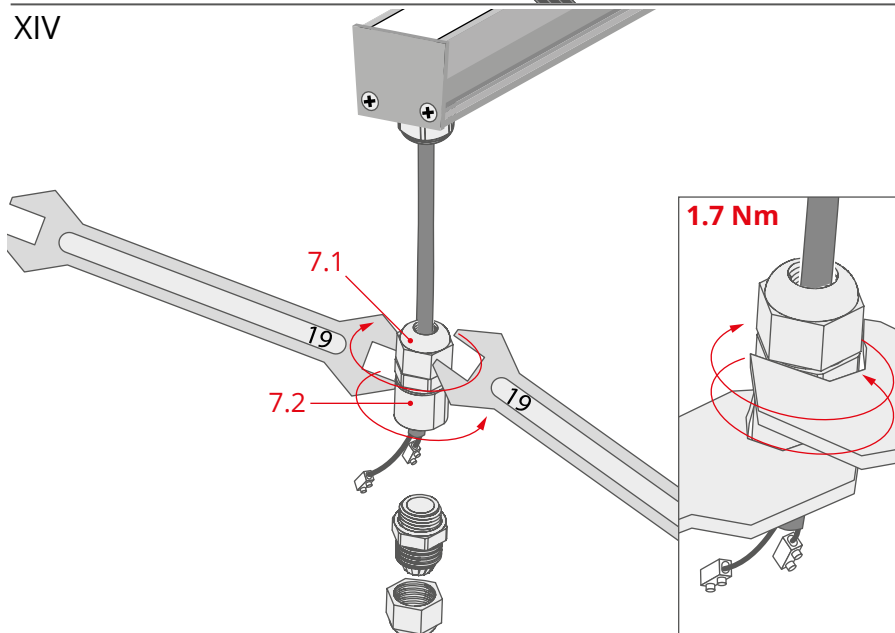

Tighten items (7.1, 7.2) of the hermetic coupler to lock them on the cable.

NOTE! The items must be tightened with torsional power equal to 1.7 Nm.

XV

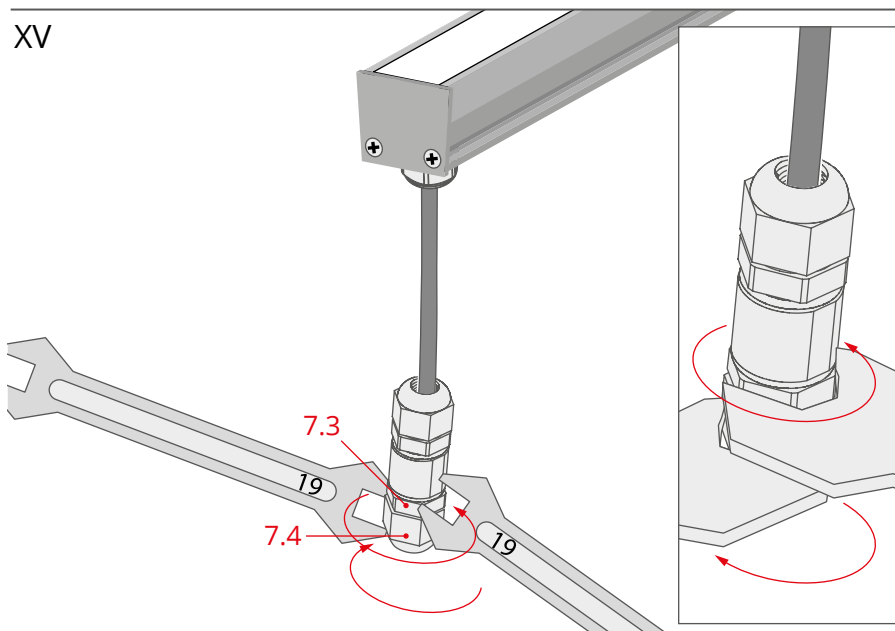

Add and tighten last two items of the hermetic coupler (7.3, 7.4).

The assembled fixture is now ready to be installed in the chosen surface.

OPTIONALLY

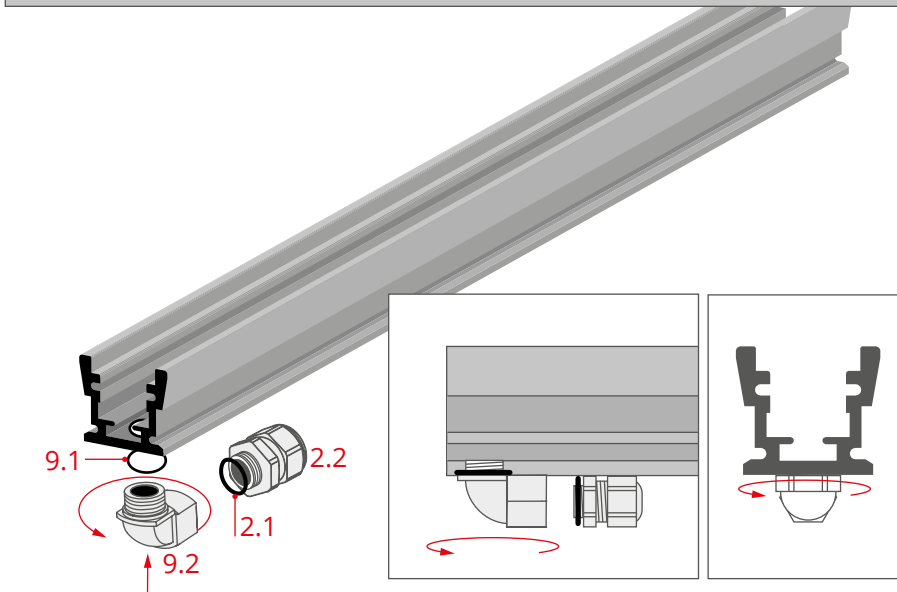

In order to facilitate the routing of cables along the fixture, it is possible to mount the optional angular gland items (9.1, 9.2) to the profile and connect them with the gland items (2.1, 2.2).

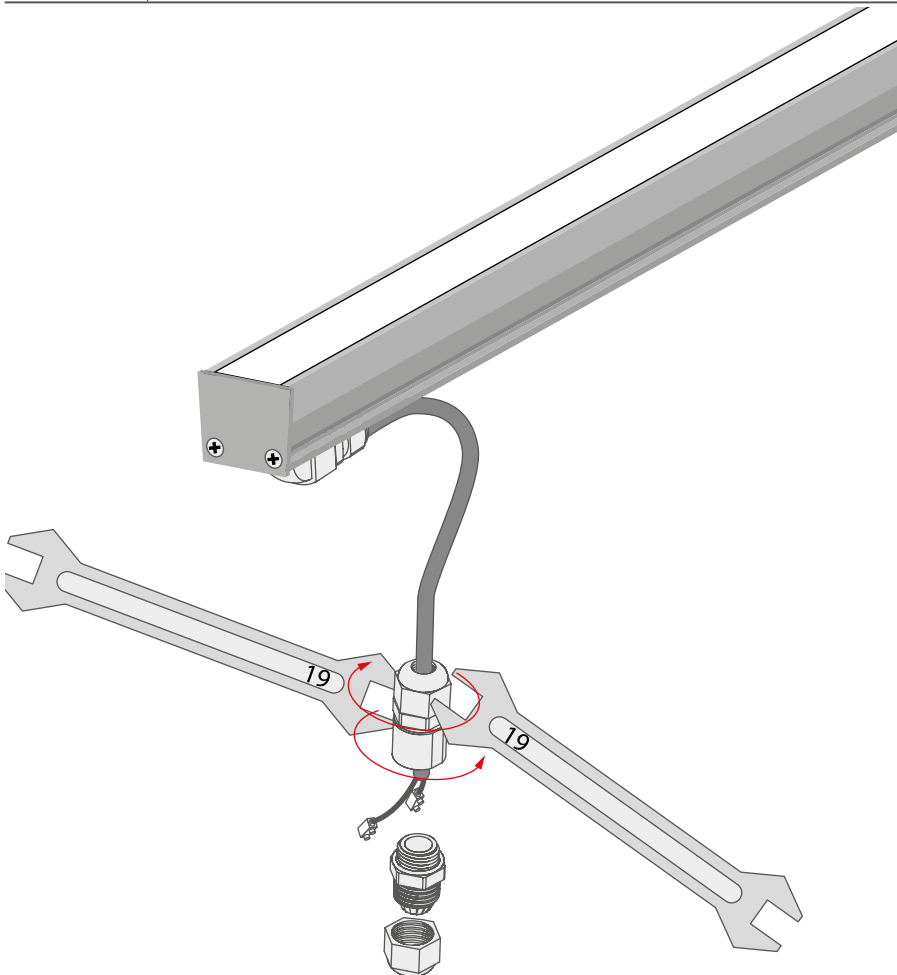

After sealing the fixture (steps VII - XII), assemble all items of the coupler in the same way as in the above steps XIII-XV.